

**Simple Wire-saving Unit for Leak Detection Sensor EX-FC1**

MJE-EXFC1 No.0052-90V

Thank you very much for purchasing Panasonic products. Please read this Instruction Manual carefully and thoroughly for the correct and optimum use of this product. Kindly keep this manual in a convenient place for quick reference.

**⚠ WARNING**

In case of using sensing devices for prevention of accidents etc. which damage a human life or properties, be sure to construct the system so that all of the machinery operates to the safety side. This product itself does not possess control functions needed for accident prevention or safety maintenance.

**1 OUTLINE**

- This is the simple wire-saving unit which can be connected with max. 8 leak detection sensors.
- Even if only one leak detection sensor is connected to this product, the output is gained when leak is detected or the sensor is mounted improperly.
- Since the exclusive snap male connector (SL-CP1) is used for connection, wire-saving can be easily made.

**2 PART DESCRIPTION**

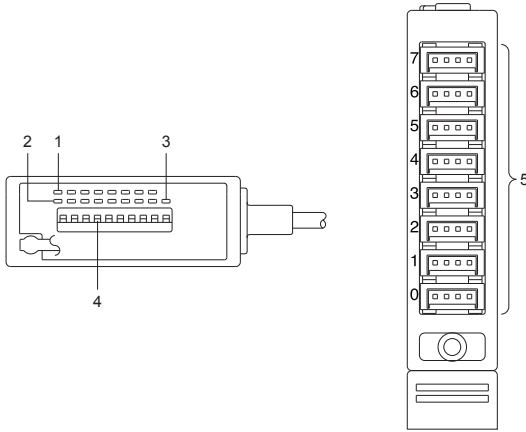

Designation	Function
1 Normal indicator (Green × 8)	Lights up when sensors are connected to each channel and the connection setting switch is set to ON.
2 Error indicator (Red × 8)	Lights up when leak is detected by any sensor connected or any sensor is mounted improperly. ( For details, refer to " <b>6 CONNECTION SETTING SWITCH.</b> " )
3 Output indicator (Orange)	Lights up when the output relay is ON (Normal).
4 Connection setting switch	Set the switch to ON when the leak detection sensor is connected, set to OFF when the leak detection sensor is not connected.
5 Connector	Connect the leak detection sensors.

**3 MOUNTING**

- When mounting the unit, be sure to use the unit mounting base (MS-SL-2) (accessory).
- When installing the unit mounting base to the unit, insert the base aligned with the grooves of the unit and move until the unit stopper is locked.

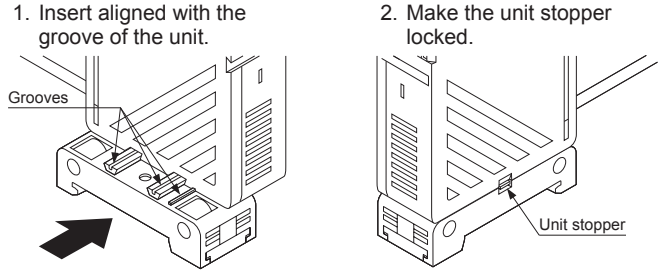

- Two installation positions are available for the unit mounting base so that the unit direction can be changed. Install the base at one of them.

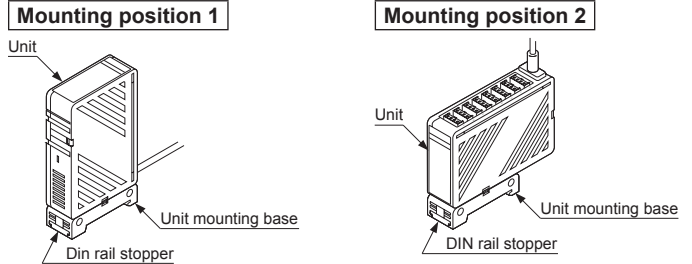

- In case of using a DIN rail or the mounting bracket (MS-DIN-3) (optional).

1. Fit the rear part of the unit mounting base on a 35mm width DIN rail or the mounting bracket (MS-DIN-3) (optional).
2. Press down the front part of the unit mounting base on the 35mm width DIN rail and fit the front part of the base on the DIN rail.

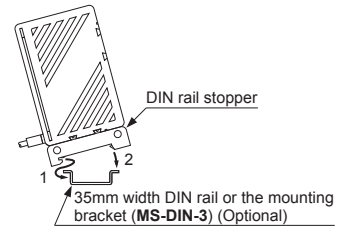

- \* For removal, insert a flathead screwdriver into the DIN rail stopper and pull towards yourself.

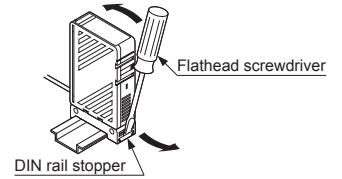

- In case of using screws

- Mount using M4 pan head screws with a tightening torque of 0.8N·m or less. However, in case of side mounting, make sure to mount the unit such that the unit stopper faces front.

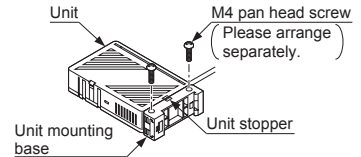

**4 I/O CIRCUIT DIAGRAM (for 1 channel)**

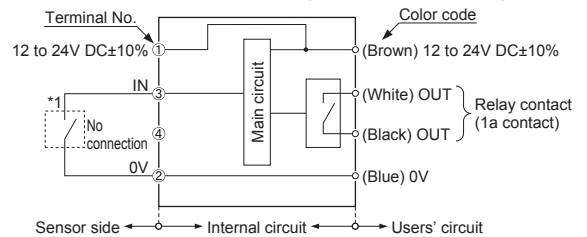

Note: Since the output does not incorporate a short-circuit protection circuit, make sure to use this product within the specification and take care against wrong wiring.

\* 1

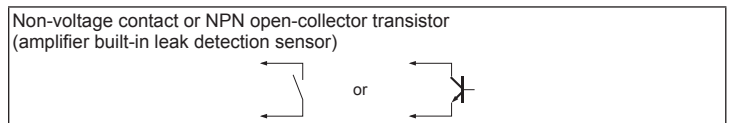

## 5 CONNECTION

- Make sure to connect or disconnect the snap male connector (SL-CP1) in the power supply off condition.
- Take care that wrong wiring will damage the product.
- The terminal No. 4 of the snap male connector (SL-CP1) is not used. Take care not to connect to the terminal No. 4 by mistake. Further, if there are unused wires, please insulate them.

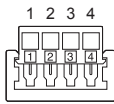

	Content
1	+V
2	0V
3	IN
4	No connected

- For details of the hook-up method of the snap male connector (SL-CP1), refer to the Instruction Manual enclosed with SL-CP1.

### Connection method

1. By holding the SL-CP1 with the cable connected, insert it into the connector of the EX-FC1 reliably till it stops.

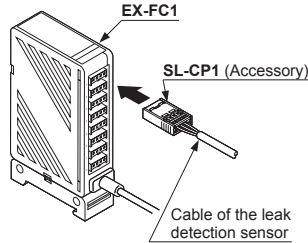

### Disconnection method

2. By holding SL-CP1, pull it from the EX-FC1 horizontally.

Note: Do not pull out by holding the cable, as this can result in cable disconnection.

## 6 CONNECTION SETTING SWITCH

The connection setting should be carried out in the power supply off condition after removing any electrostatic charge which may be present on your body.

### Operation matrix for each indicator

Operation	Connection state of the leak detection sensor	State of the connection setting switch	Leak detected condition	Normal indicator (Green)	Error indicator (Red)	Output indicator (Orange)
Normal	Connected	ON	Not leaked	Lights up	Turns off	Lights up
	Unconnected	OFF	Leaked	Turns off	Lights up	Turns off
Error	Connected	OFF	Not leaked	Lights up	Lights up	Turns off
	Unconnected	ON	Leaked	Turns off	Lights up	Turns off

- For the channel that the unit sensor is connected to and the connection setting switch is set to "ON" side, the error indicator (red) lights up for a moment when the power is turned on. This is not a malfunction for the unit because it is caused by characteristic of the sensor.
- Make sure to set the connection setting switch with the connector No. to which the leak detection sensor is connected, to "ON" side.
- In case both the normal indicator (green) and the error indicator (red) light up, the connection setting switch with the connector No. to which the leak detection sensor is connected, is not set to "ON" side. Set the connection setting switch with the connector No. to which the leak detection sensor is connected, to "ON" side.
- In case the error indicator (red) lights up, the leak detection sensor detects leak or the connection setting switch is set to "ON" side without connecting the leak detection sensor. If the connection setting switch is set to "ON" side without connecting the leak detection sensor, set the connection setting switch to "OFF" side.
- If the leak detection sensor detects leak or the connection setting switch is set to "OFF" side in the state that the leak detection sensor is improperly mounted to the mounting bracket, the sensor judges as the output is ON. Be careful when setting.

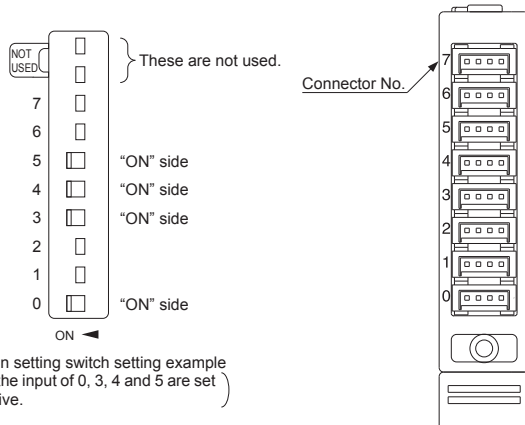

## 7 SPECIFICATIONS

Item	Designation	Simple wire-saving unit for leak detection sensor
	Model No.	EX-FC1
Applicable connector		SL-CP1
Supply voltage		12 to 24V DC±10 % Ripple P-P 10% or less
Current consumption		50mA or less (for one unit) 135mA or less (including the sensor input current when all outputs are ON)
Output	Relay contact 1a	<ul style="list-style-type: none"> <li>• Switching capacity: 30V 1A DC (resistant load)</li> <li>• Min. applied load: 10mV 10µA DC</li> <li>• Electrical lifetime: 100,000 times or more (rated load, switching frequency 20 times/min.)</li> <li>• Mechanical lifetime: 50,000,000 times or more (switching frequency 180 times/min.)</li> </ul>
	Output operation	The output relay is ON when the input signal from the sensor is ON.
Response time		5ms or less (excluding the response time of the sensor)
Input points		8 points
Ambient temperature		-10 to +60°C (No dew condensation or icing allowed) Storage: -20 to +70°C
Ambient humidity		35 to 85% RH, Storage: 35 to 85% RH
Material		Enclosure: ABS, Terminal part: PBT
Cable		0.2mm <sup>2</sup> 4-core cabtyre cable, 2m long
Weight		Approx. 85g
Accessory		SL-CP1 (Snap male connector): 8 pcs. MS-SL-2 (Unit mounting base): 1 pc.

## 8 CAUTIONS

- This product has been developed / produced for industrial use only.
- This product is suitable for indoor use only.
- Avoid using the product in an explosive atmosphere because this product does not have an explosive-proof protective construction.
- Make sure that the power supply is off while wiring.
- Take care that wrong wiring will damage the product.
- Verify that the supply voltage variation is within the rating. Take care that if a voltage exceeding the rated range or an AC power supply is directly applied, the sensor may get damaged or burnt.
- If power is supplied from a commercial switching regulator, ensure that the frame ground (F.G.) terminal of the power supply is connected to an actual ground.
- In case noise generating equipment (switching regulator, inverter motor, etc.) is used in the vicinity of this product, connect the frame ground (F.G.) terminal of the equipment to an actual ground.
- Do not run the wires together with high-voltage lines or power lines or put them in the same raceway. This can cause malfunction due to induction.
- Do not use during the initial transient time (approx. 0.5 sec.) after the power supply is switched on.
- Cable extension is possible up to total 10m with 0.3mm<sup>2</sup>, or more, cable. However, in order to reduce noise, make the wiring as short as possible.
- Make sure that stress by forcible bend or pulling is not applied to the cable joint.
- Since the output does not incorporate a short-circuit protection circuit, make sure to use this product within the specification and take care against wrong wiring.
- In case a surge is generated in the used power supply, connect a surge absorber to the supply and absorb the surge.
- Make sure to use an isolation transformer for the DC power supply. If an auto-transformer (single winding transformer) is used, this product or the power supply may get damaged.
- Avoid dust, dirt, and steam.
- Take care that the product does not come in contact with oil, grease or organic solvents, such as, thinner, etc., strong acid or alkaline.
- This sensor is suitable for indoor use only.

## 9 INTENDED PRODUCTS FOR CE MARKING

- The models listed under "7 SPECIFICATIONS" come with CE Marking. 
- As for all other models, please contact our office.
- **Contact for CE**  
Panasonic Marketing Europe GmbH Panasonic Testing Center  
Winsbergring 15, 22525 Hamburg, Germany

## Panasonic Industrial Devices SUNX Co., Ltd.

<http://panasonic.net/id/pidsx/global>

Overseas Sales Division (Head Office)

2431-1 Ushiyama-cho, Kasugai-shi, Aichi, 486-0901, Japan  
Phone: +81-568-33-7861 FAX: +81-568-33-8591

For sales network, please visit our website.

PRINTED IN JAPAN

© Panasonic Industrial Devices SUNX Co., Ltd. 2015